

# **DESIGN OF WOMEN SAFETY SYSTEM USING RFID AND GSM TECHNOLOGY**

*Dissertation submitted in partial fulfillment of the requirement for the degree of*

**BACHELOR OF TECHNOLOGY  
IN  
ELECTRONICS AND COMMUNICATION ENGINEERING  
BY**

Mehak Gupta(121095)

Swati Thakur (121102)

Lakshdeep Singh(121105)

Under the supervision of

**Mrs Vanita Rana**



JAYPEE UNIVERSITY OF INFORMATION TECHNOLOGY, WAKNAGHAT

**June 2016**

# TABLE OF CONTENTS

<b>Chapter no.</b>	<b>Page Number</b>
<b>DECLARATION BY THE SCHOLAR</b>	<b>iv</b>
<b>SUPERVISOR'S CERTIFICATE</b>	<b>v</b>
<b>ACKNOWLEDGEMENT</b>	<b>vi</b>
<b>LIST OF FIGURES</b>	<b>vii</b>
<b>LIST OF TABLES</b>	<b>viii</b>
<b>LIST OF ABBREVIATIONS</b>	<b>ix</b>
<b>ABSTRACT</b>	<b>x</b>
<b>CHAPTER 1            INTRODUCTION</b>	<b>1</b>
1.1    EXISTING SYSTEM	1
1.2    BLOCK DIAGRAM	2
1.3    FLOW CHART	3
1.4    REQUIREMENTS	4
<b>CHAPTER 2            LITERATURE REVIEW</b>	<b>5</b>
<b>CHAPTER 3            HARDWARE DESCRIPTION</b>	<b>7</b>
3.1    ATMEGA328 MICROCONTROLLER	7
3.2    RADIO FREQUENCY AND IDENTIFICATION	7
3.3    GSM	8
3.3.1    SIM CARD	8

3.3.2	SMS	9
<b>CHAPTER 4</b>	<b>COMPARISON OF USED TECHNOLOGY OVER OTHER</b>	<b>12</b>
4.1	AVR OVER OTHER	12
4.2	RFID OVER OTHER TECHNOLOGY	13
4.3	WHY USE GSM MODEM	14
<b>CHAPTER 5</b>	<b>RFID INTERFACING WITH ATMEGA328</b>	<b>15</b>
5.1	INTRODUCTION	15
5.2	PRINCIPLE OF RFID	15
5.3	WORKING OF RFID	16
5.4	PIN OUT	18
5.5	CIRCUIT	19
5.6	ARDUINO SERIAL MONITOR RFID OUTPUT	20
<b>CHAPTER 6</b>	<b>GSM INTERFACING WITH ATMEGA328</b>	
6.1	INTRODUCTION	21
6.2	GSM NETWORK ARCHITECTURE	22
6.3	STEPS TO INTERFACE MODEM WITH MICROCONTROLLER	25
6.4	CIRCUIT DIAGRAM	26
<b>CHAPTER 7</b>	<b>RESULTS AND CONCLUSIONS</b>	<b>27</b>
<b>REFERENCES</b>		<b>28</b>
<b>APPENDIX</b>		
APPENDIX 1	MICROCONTROLLER ATMEGA328 DATASHEET	<b>29</b>
APPENDIX 2	CODE	31

## ***DECLARATION BY THE SCHOLAR***

I hereby declare that the work reported in the B-Tech thesis entitled“ **Design of women safety system using RFID and GSM based technology**”submitted at **Jaypee University of Information Technology,Waknaghat India**,is an authentic record of my work carried out under the supervision of **MRS. Vanita rana**. I have not submitted this work elsewhere for any other degree or diploma.

MEHAK GUPTA

SWATI THAKUR

LAKSHDEEP SINGH

## **SUPERVISOR'S CERTIFICATE**

This is to certify that the work reported in the B-Tech. thesis Entitled "**Design of women safety system using RFID and GSM based technology**", submitted by **SWATI THAKUR, MEHAK GUPTA, LAKSHDEEP SINGH** at **Jaypee University of Information Technology, Waknaghat, India**, is a bonafide record of his / her original work carried out under my supervision. This work has not been submitted elsewhere for any other degree or diploma.

Mrs Vanita Rana

(Assistant Professor)

## ACKNOWLEDGEMENT

While working on this project, we had a great fortune to meet and collaborate with many great people. First and foremost, we would like to acknowledge and thank our supervisor **Mrs. Vanita Rana**, for her invaluable advice, guidance and patience. She has made a great contribution toward sharpening our ability to solve scientific problem by careful and complete examination and evaluation of the work undertaken in the report.

We acknowledge the support of Prof. Sunil Bhooshan, Head of Department of Electronics and Communication Engineering, for providing us the necessary facilities for doing this work.

We also have benefitted enormously from valuable discussions with our fellow students.

Finally, we would like to thank our parents for their support and contribution to our education in early stages of our life, as they were the inspiration for our genuine interest in science and engineering during our childhood years. We thank them for their untiring support and valuable guidance in this endeavor

Mehak Gupta

Swati Thakur

Lakshdeep Singh

## LIST OF FIGURES

<b>Figure No.</b>	<b>Caption</b>	<b>Page No.</b>
Figure 1.1	BLOCK DIAGRAM	2
Figure1.2	FLOW CHART OF DESIGN SYSTEM	3
Figure 3.1	FUNCTIONING OF SMS	10
Figure 4.1	ATMEGA328 MICROCONTROLLER	12
Figure 5.1	RFID SYSTEM PRINCIPLE	15
Figure 5.2	RFID SYSTEM PRINCIPLE (2)	16
Figure 5.3	ACTIVE RFID TAG BLOCK DIAGRAM	17
Figure 5.4	PASSIVE RFID TAG BLOCK DIAGRAM	17
Figure 5.5	EM-18 RFID READER MODULE – BOTTOM VIEW	18
Figure 5.6	RFID INTERFACING WITH AVR	19
Figure 5.7	INTERFACE EM18 RFID READER WITH ARDUINO	19
Figure 6.1	GSM SIM900A	21
Figure 6.2	SIM900A MODULE	22
Figure 6.3	GSM SYSTEM ARCHITECTURE	23
Figure.6.4	CIRCUIT FOR GSM INTERFACING WITH ARDUINO	26

## LIST OF TABLES

<b>Table no.</b>	<b>Caption</b>	<b>Page no.</b>
Table 4.1	Comparison of architecture of various microcontroller families	13
Table 5.1	Pin description of RFID EM18	18



## **LIST OF ABBREVIATIONS USED**

DTE	Data terminal equipment
EEPROM	Electrically Erasable Programmable Read-Only Memory
ISP	In-system programming
GPS	Global Positioning System
GPRS	General Packet Radio Service
GSM	Global System for Mobile Communication
RISC	Reduced Instruction Set Computer
RFID	Radio Frequency Identification
SIM	Subscriber Identity Module
SMS	Short Message Service
TTL	Transistor-transistor logic
UART	Universal Asynchronous Receiver/Transmitter

## **ABSTRACT**

Today in the current global scenario, the prime question in every girl's mind, taking into account the ever rising increase of issues on women harassment in recent past, is only about her safety and security. The only thought haunting every girl is when they will be able to move freely on the streets even in odd hours without worrying about their security. Even in the 21st century where the technology is rapidly growing and new gadgets were developed but still women and girls are facing problems.

This thesis suggests a new perspective to use technology to protect women. The implementation of women security system via RFID and GSM serves the purpose. The proposed system is especially for women safety and overcomes the disadvantages of existing systems. In this proposed system when the women are in danger it can be intimated immediately to respective persons using GSM technology. In case of any harassment, the women wearing a band or pendent is embed with active RFID tag, as she brings it near to the circuitry the information is passed to RFID reader which communicates with ATmega328 microcontroller and through GSM the "help" message is sent to 4 predefined contacts(parents, friends, media, women cell)..

The basic approach is to send a distress message to the cops and registered number; hence the sim can be traced by the cops thus averting the unfortunate incidents. In this project we will implement women safety system on ATMEGA328 microcontroller via GSM modem and RFID module. This is an inexpensive device which reduces the problem associated with accident notification

## **INTRODUCTION**

In today's world, women safety has become a major issue as they can't step out of their house at any given time due to physical/sexual abuse and a fear of violence. Even in the 21st century where the technology is rapidly growing and new gadgets were developed but still women and girls are facing problems. Even today in India, women can't move at night in secluded places and even at day time crowded places hundreds and thousands of incidents of physical/sexual abuse happens to every day women in this country. Among other crimes, rape is the fastest growing crime in the country today. In this paper we have implemented women safety system on atmega328 microcontroller via GSM modem and RFID module.

### **1.1 EXISTING SYSTEM**

Keeping the same concern in mind many developers have come up with innovative applications. Few of such applications are as follows-

1. VithU app: This is an emergency app initiated by a popular Indian crime television series "Gumrah" aired on Channel [V]. In this app when the power button of the Smartphone is pressed twice consecutively, it will begin sending out alert messages with a link to the location of the user every two minutes to the contacts fed into the app.
2. SHE (Society Harnessing Equipment) : It is a garment designed by three engineers from Chennai. This garment has an electric circuit that can generate 3800kv of current which can help the victim to escape. In case of multiple attacks it can send upto 82 electric shocks. Since the fabric is bilayer, the user is not affected. It can also send emergency messages.
3. ILA security: The co-founders of this system, Mc Givern, James Phillips, and Neil Munn , have designed three personal alarms that can shock and disorient potential attackers and draw attention to dangerous situations.

## 1.2 BLOCK DIAGRAM

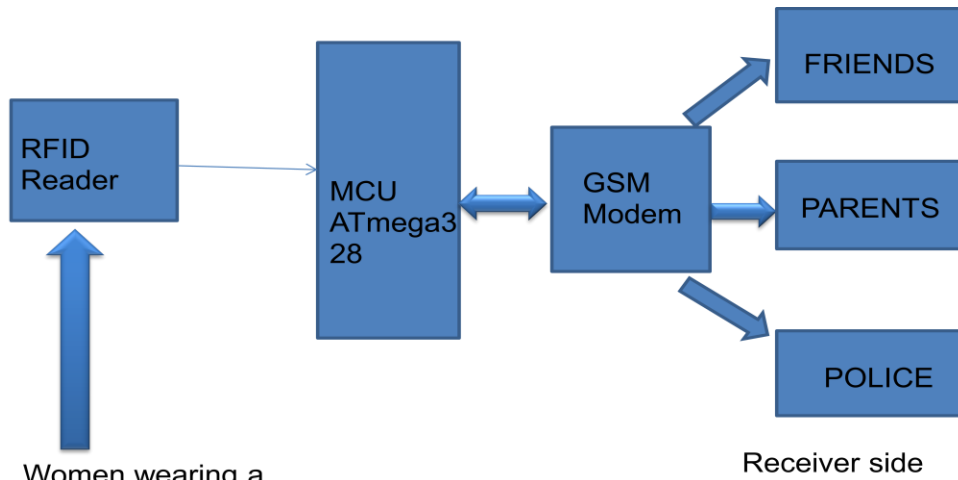

Women wearing a watch or band with embedded RFID tag

Figure 1: Women safety system transmitter side

### 1.3 FLOW CHART

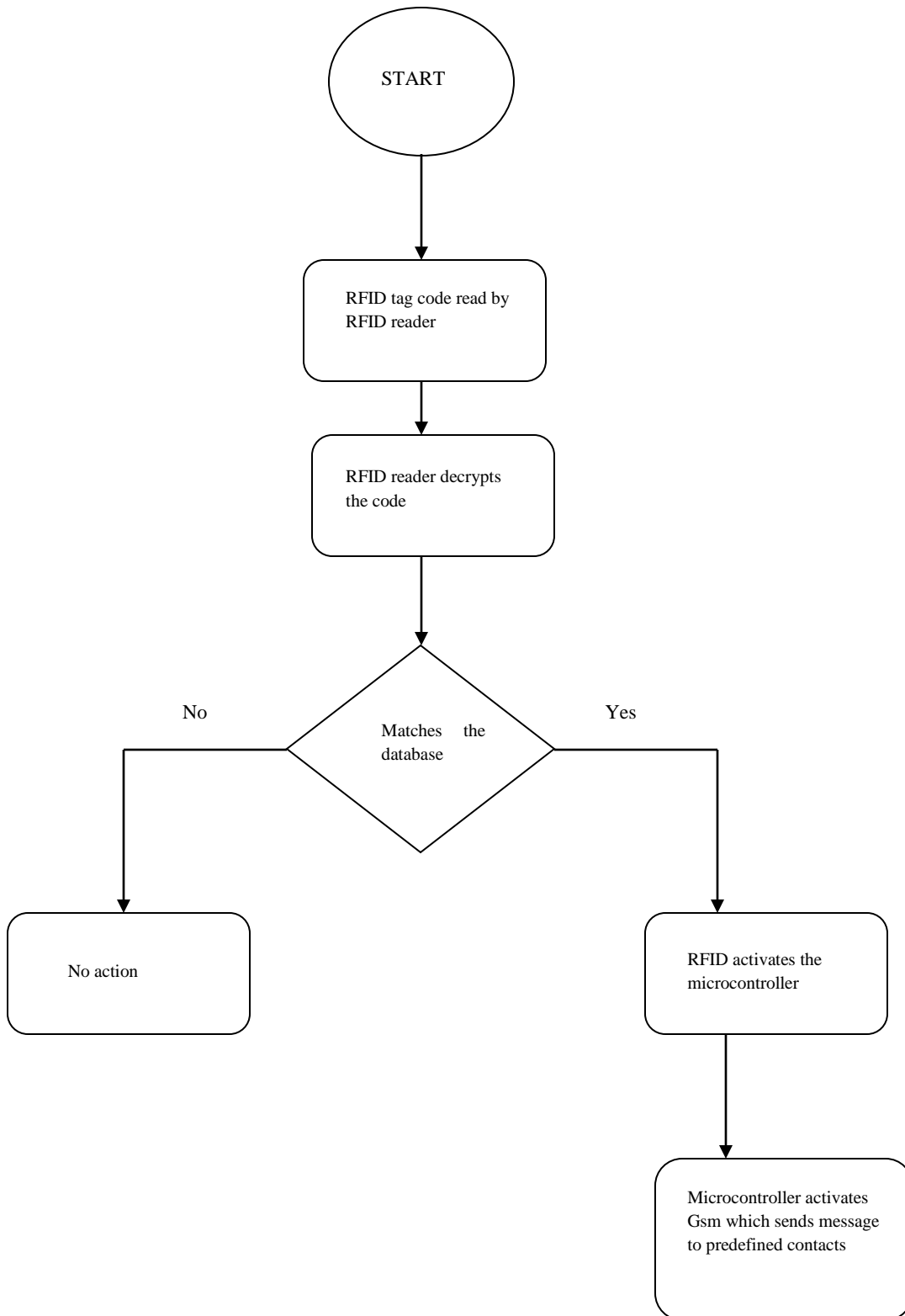

Fig.1.2 Flow chart of design system

## **1.4 REQUIREMENTS**

### **Hardware requirements:**

1. Microcontroller ATMEGA328
2. RFID Module(EM18)
3. GSM Module(SIM900A)
4. Capacitors
5. Resistors
6. Jumper Wires
7. Printed Circuit Board
8. Connectors
9. 5V power supply

### **Software requirements.:**

1. Programming in Arduino C
2. Arduino Software
3. Burner

## **LITERATURE REVIEW**

### **1. Design of women safety system using RFID,8051microcontroller and GSM based technology a Prototype by Shaik Mazhar Hussain1, Shaik Jhani Bhasha2**

The women wearing a watch or band when finds that someone is going to harass, she presses a switch that is located on the watch or band which then activates the active RFID tag and then the signal gets transmitted to RFID reader which then decodes the received information (either some code or name) and then activates the AT89C51 microcontroller in which contacts of 4 people and message “HELP” is stored in memory is sent to the destination through GSM. In this paper women safety system is implemented on AT89C51 microcontroller via GSM modem and RFID module and the interfacing is done through MAX-RS 232

### **2. Design and Development of “Suraksha”-A Women Safety Device by Nishant Bhardwaj1 and Nitish Aggarwal**

The device, named as “**Suraksha**” is a security system specially designed for women in distress. It is a simple and easy to carry device with magnanimous functionality. The basic approach is to intimidate instant location and a distress message to the cops and registered number, so that unfortunate incidents would be averted and to provide real time evidence for swift action against the perpetrators of crime against women. Currently the work is under process to miniaturize it so that it could be embedded in jewellerys, mobile phones etc in order to make it a versatile instrument for masses. It can play a major role in the upcoming projects such as **CCTNS (crime and criminal tracking network and system)** in which all the police records all over India are digitised and all the police station throughout the country will be integrated.

### **3. Application for Women Safety by 1S.Sangeetha, 2P.Radhika PG Scholar, Department of MCA, Panimalar Engineering College**

This project presents an alert system for Women safety detection using common commercially available electronic devices to both detect the problem and alert authorities. An Android based smart phone is used with an integrated features that alert and provide location based information to alert authorities. Data from the application is evaluated with several threshold based AES algorithms and position data to determine a problem. The system provides a realizable, cost effective solution to problem detection using a simple graphical interface while not overwhelming the user with uncomfortable sensors. Problem is very powerful software especially developed for the safety of girls, whenever some body is in trouble they don't have to sit and find contacts or find ways to send short message service, or message the near ones. They

might not have so much time.. All that they have to do is shake the smart phone above the threshold value, vigorously. Immediately a message alert is sent to the person's mom, dad and whoever they wish to, if their guardians also have a smart phone. Even though if it is in silent mode. When a message called alert is received it automatically changes its profile to general, and gives a message notification YOUR DAUGHTER IS IN TROUBLE PLZ HELP.... PLZ HELP.... PLZ HELP.... REPEATEDLY AS A message until they seen and stop it.. Now a day security of women is becoming very poor and the need for this kind of application is steadily increasing work wise, further looking forward to develop a routine schedule based mechanism to monitor the women's security using GPS (Global Positioning System), GPRS (General Packet Radio Service), etc....



### **HARDWARE DESCRIPTION**

In this project we used ATMEGA328 microcontroller. It mainly controls the all functions of the project. GSM modem is used to send messages to the predefined numbers stored in the microcontroller. RFID reader is used to communicate with RFID tags by receiving and transmitting signals.

#### **3.1 ATmega328 controller:**

The high-performance Atmel 8-bit AVR RISC-based microcontroller combines 32KB ISP flash memory with read-while-write capabilities, 1KB EEPROM, 2KB SRAM, 23 general purpose I/O lines, 32 general purpose working registers, three flexible timer/counters with compare modes, internal and external interrupts, serial programmable USART, a byte-oriented 2-wire serial interface, SPI serial port, 6-channel 10-bit A/D converter (8-channels in TQFP and QFN/MLF packages), programmable watchdog timer with internal oscillator, and five software selectable power saving modes. The device operates between 1.8-5.5 volts.

By executing powerful instructions in a single clock cycle, the device achieves throughputs approaching 1 MIPS per MHz, balancing power consumption and processing speed.

#### **3.2 Radio-frequency identification and detection:**

An RFID (Radio-frequency identification and detection) reader is a device which is used to communicate with RFID tags by receiving and transmitting signals. These signals use radio waves for wireless communication. RFID tag is applied to products, individuals or animals to identify and track them. The identification is done through a unique serial number. This topic covers the interfacing of a passive RFID system with ATMEGA328. An RFID module basically consists of two parts, namely, a tag and a reader. A typical RFID system consists of an antenna, a transceiver and a transponder (RF tag). The radio frequency is read by the transceiver and the information is transferred to a device for further processing. The information (the unique serial number) to be transmitted is stored in the RF tag or transponder. The transponder contains a chip and an antenna mounted on a substrate. The chip transmits the relevant information through antenna.

The antenna also receives the electromagnetic waves sent by the RFID reader.

Different RFID tags work on different frequencies. Here low frequency, 125 kHz, RFID tags have been used. These tags work within a range of 10 cm. When an RFID tag comes in this range, the reader detects it and sends a unique code of the tag serially. This serial code, consisting of 12 bytes, is received by the microcontroller.

### **3.3 GSM (Global System for Mobile Communication)**

GSM stands for Global System for Mobile Communications. It is a standard set developed by the European Telecommunications Standards Institute (ETSI) to describe protocols for second generation (2G) digital cellular networks used by mobile phones.

A Modem is a device which modulates and demodulates signals as required to meet the communication requirements. It modulates an analogue carrier signal to encode digital information, and also demodulates such a carrier signal to decode the transmitted information.

A GSM Modem is a device that modulates and demodulates the GSM signals and in this particular case 2G signals. The modem SIMCOM SIM300 is a Tri-band GSM/GPRS Modem as it can detect and operate at three frequencies (EGSM 900 MHz, DCS 1800 MHz and PCS1900 Mhz). Default operating frequencies are EGSM 900MHz and DCS 1800MHz.

Sim300 is a widely used in many projects and hence many variants of development boards for this have been developed. These development boards are equipped with various features to make it easy to communicate with the SIM300 module. Some boards provide only TTL interface while some boards include an RS232 interface and some others include an USB interface. Sim300 GSM module used here, consists of a TTL interface and an RS232 interface. The TTL interface allows us to directly interface with a microcontroller while the RS232 interface includes a MAX232 IC to enable communication with the PC. It also consists of a buzzer, antenna and SIM slot. Sim300 in this application is used as a DCE (Data Circuit-terminating Equipment) and PC as a DTE (Data Terminal Equipment).

#### **3.3.1 SIM CARD**

A SIM card, also known as a subscriber identity module, is a smart card that stores data for GSM cellular telephone subscribers. Such data includes user identity, location and phone number, network authorization data, personal security keys, contact lists and stored text messages. Security features include authentication and encryption to protect data and prevent eavesdropping.

A SIM card can be switched easily from one phone set to another. The portability of data offers a number of benefits. For example, a user that buys a new phone can install the current SIM card to associate the new phone with the same number and user preferences as the old one. In another common situation, if a phone's battery runs out of power, the user can easily install the card to another subscriber's phone to borrow it without running up that user's minutes. Some vendors

offer prepaid SIM cards that can provide travelers with local numbers, as long as their cell phones are not locked to a specific carrier.

### **Functionality of the SIM card**

The SIM card performs the following valuable functions:

**1) Identification of a subscriber:** The IMSI programmed on the SIM card, is the identity of a subscriber. Each IMSI is mapped to a mobile number and provisioned on the HLR to allow a subscriber to be identified.

**2) Authentication of a subscriber:** This is a process, where, using the authentication algorithm (COMP128V3 for 2/2.5 G GSM, CAVE for CDMA and Milenage for 3G) on the SIM card, a unique response is provided by each subscriber based on IMSI, Ki (stored on SIM) and RAND (provided by network). By matching this response with values computed on the network a legal subscriber is logged on to the network and he or she can now make use the services of the mobile service provider.

**3) Storage:** To store phone numbers and SMS. **4) Applications:** The SIM Tool Kit or GSM 11.14 standard allows creating applications on the SIM to provide basic information on demand and other applications for m-commerce, chatting, cell broadcast, phonebook backup, location based services etc.

### **3.3.2 SMS(Short Message Service)**

#### **Introduction**

Short message service is a mechanism of delivery of short messages over the mobile networks. It is a store and forward way of transmitting messages to and from mobiles. The message (text only) from the sending mobile is stored in a central short message center (SMS) which then forwards it to the destination mobile. This means that in the case that the recipient is not available, the short message is stored and can be sent later. Each short message can be no longer than 160 characters. These characters can be text (alphanumeric) or binary Non-Text Short messages. An interesting feature of SMS is return receipts. This means that the sender, if wishes, can get a small message notifying if the short message was delivered to the intended recipient. Since SMS used signaling channel as opposed to dedicated channels, these messages can be sent/received simultaneously with the voice/data/fax service over a GSM network. SMS supports national and international roaming. This means that you can send short messages to any other GSM mobile user around the world. With the PCS networks based on all the three technologies, GSM, CDMA and TDMA supporting SMS, SMS is more or less a universal mobile data service.

## How does SMS work

The figure below shows a typical organization of network elements in a GSM network supporting SMS.

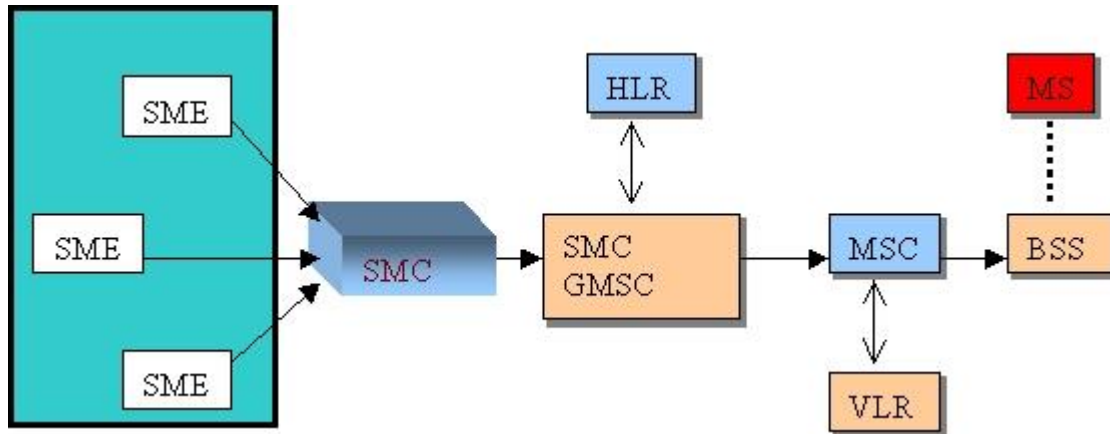

Fig. 3.1 Functioning of SMS

The SMC (Short Message Center) is the entity which does the job of store and forward of messages to and from the mobile station. The SME (Short Message Entity) which can be located in the fixed network or a mobile station, receives and sends short messages.

The SMS GWMS (SMS gateway MSC) is a gateway MSC that can also receive short messages. The gateway MSC is a mobile network's point of contact with other networks. On receiving the short message from the short message center, GMSC uses the SS7 network to interrogate the current position of the mobile station form the HLR, the home location register.

HLR is the main database in a mobile network. It holds information of the subscription profile of the mobile and also about the routing information for the subscriber, i.e. the area (covered by a MSC) where the mobile is currently situated. The GMSC is thus able to pass on the message to the correct MSC.

MSC (Mobile Switching Center) is the entity in a GSM network which does the job of switching connections between mobile stations or between mobile stations and the fixed network.

A VLR (Visitor Location Register) corresponds to each MSC and contains temporary information about the mobile, information like mobile identification and the cell (or a group of

cells) where the mobile is currently situated. Using information from the VLR the MSC is able to switch the information (short message) to the corresponding BSS (Base Station System, BSC + BTSs), which transmits the short message to the mobile. The BSS consists of transceivers, which send and receive information over the air interface, to and from the mobile station. This information is passed over the signaling channels so the mobile can receive messages even if a voice or data call is going on.

## **Applications**

Some of the common applications of SMS are:

- Exchanging small messages like "See you at 8.30 tonight at xyz". SMS is particularly suited for these kinds of short messages because SMS is much cheaper than calling someone and giving the same message. Calling someone to give the same message would invariably take more time and hence more cost.
- Many operators offer e-mail service over SMS. Every user is assigned an e-mail address at signup and any message delivered to that email is converted to short messages and delivered to the mobile.
- It is possible to send e-mail messages (less than 160 characters) from a mobile phone to any e-mail address via SMS.
- Information services like news, weather, entertainment and stock prices etc. can be availed just by sending a keyword like NEWS, WEATH etc to the short message center number.
- SMS can be used by the network operators to provide services like balance enquiry in case of prepaid cards using SMS.
- Mobile chatting is one more hot application of SMS
- SMS can be used to notify users that they have received new voice-mail or fax messages.
- It provides an alternative to alphanumeric paging services
- Using SIM-Toolkit, now a part of GSM specifications, SMS can be used to have on the air activation of features. By sending codes embedded in short messages from the server network operators can remotely provision the user's wireless terminal
- Internet e-mail alerts.
- Downloading new ring tones.

### COMPARISON OF USED TECHNOLOGY OVER OTHER

#### 4.1 Why use AVR microcontrollers over other:

- AVR has RISC architecture
  - i. Reduced Instruction Set Computers (RISCs) offer more performance per transistor than conventional Complex Instruction Set Computers (CISCs).
  - ii. The RISC approach allows 32 bit processing power to be offered at much lower cost than was possible with a CISC, because of the smaller die size required to implement the processor. The availability of this power allows system functionality to be moved from hardware to software, which in turn simplifies the support chips and further reduces system cost.
  - iii. RISC architecture processors / micro-controllers take a fixed number of cycles to execute an instruction. Their instructions are also fixed size.
- AVR has Pipe lined processors resulting in faster execution ( 1 IPC compared to 1/12 IPC of 8051 )
- 8051 has 8 Eight bit Registers and has 4 banks , only one of which is usable at any time. AVR have 32 Eight bit Registers thus better than 8051 family.
- AVR has GCC compilers and a lot of open source software support. Arduino and others have made AVR a little more approachable.

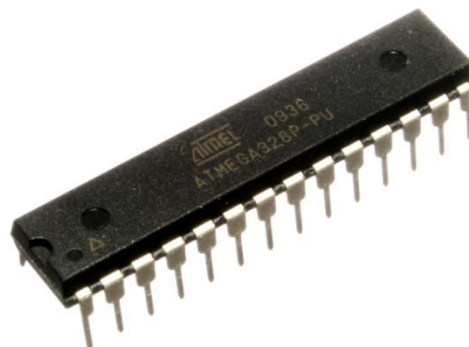

Fig 4.1 ATMEGA328 MICROCONTROLLER

The table mentioned compares the architecture of various families.

	8051	AVR	PIC	MSP430
Bus Width	8 bit for standard core	8/32 bit	8/16/32 bit	16 bit
Communication Protocols	UART,USART,SPI,12C	UART,USART,SPI,12C (Special purpose AVR support CAN,USB,Ethernet)	PCI,Uart,USART, LIN,CAN,Ethernet,SPI	UART, USART, LIN, 12C, SPI
Speed	12 Clock/instruction cycle	1 clock/instruction cycle	4 clock/instruction cycle	6 clock/instruction cycle
Memory	ROM,SRAM,FLASH	Flash SRAM,EEPROM	SRAM Flash	SRAM Flash
ISA	CISC	RISC	Some feature of RISC	Some feature of RISC
Memory Architecture	Von Neumann architecture	Modified Harvard	Harvard architecture	Von Neumann architecture
Power Consumption	Average	Low	Low	Ultra Low
Families	8051 variants	ATMega,Xmega special purpose AVR	PIC16,PIC17,PIC18,PIC24, PIC32	MSP430X, MSP430X1XX- MSP430X0XX
Community	Vast	Very Good	Very Good	Average
Cost	Very Low	Average	Average	Average
Other Feature	Known for its standard	Cheap, effective	Cheap	Known for ultra low power operation

Table 4.1 Comparison of architecture of various microcontroller families

## 4.2 Why use RFID over other technologies?

- No line of sight requirement.
- The tag can stand a harsh environment.
- Long read range.
- Portable database.
- Multiple tag read/write.

Other than RFID module a finger print scanner could have been used to but it suffers various problems such as:

- i. Using the fingerprint scanner does not take into consideration when a person physically changes.

- ii. The cost of computer hardware and software programs can be expensive.
- iii. Using the fingerprint scanner can lead to false rejections.
- iv. Using the fingerprint scanner can lead to false acceptances

### **4.3 Why use a GSM Modem?**

GSM Technology has grown so much, that literally there isn't a place on earth where there is no GSM signal. In such a scenario GSM provides us a wide scope in controlling things remotely from any place just with our finger tips. GSM also provides ease to easily communicate in a more robust way. We have used SIM900A GSM in this project.

#### **Features of GSM modem:-**

- High Quality Product- SIM900A
- Frequency – 900/1800 MHz.
- Modem interface- RS232 Serial interface
- Configurable baud rate
- Wire antenna (SMA connector with GSM antenna optional) with SIM card holder
- Built in network status LED
- Inbuilt powerful TCP/IP Protocol stack internet data transfer over GPRS
- Normal operation temperature : -20 C to +55 C
- Power Management : 4.5V -12V DC

#### **Applications**

- SMS based Remote Control & Alerts
- Security Applications
- Sensor Monitoring
- GPRS Mode Remote Data Logging
- GSM controlled devices



## RFID INTERFACING WITH ATMEGA328

### 5.1 INTRODUCTION

Arduino is an open source physical computing platform based on ATmega328 microcontroller and provides a development environment for writing software for the board. It can be used for a variety of projects.

EM-18 RFID reader is one of the commonly used RFID reader to read 125KHz tags. It features low cost, low power consumption, small form factor and easy to use. It provides both UART and Wiegand26 output formats. It can be directly interfaced with microcontrollers using UART and with PC using an RS232 converter.

### 5.2 PRINCIPLE OF RFID:

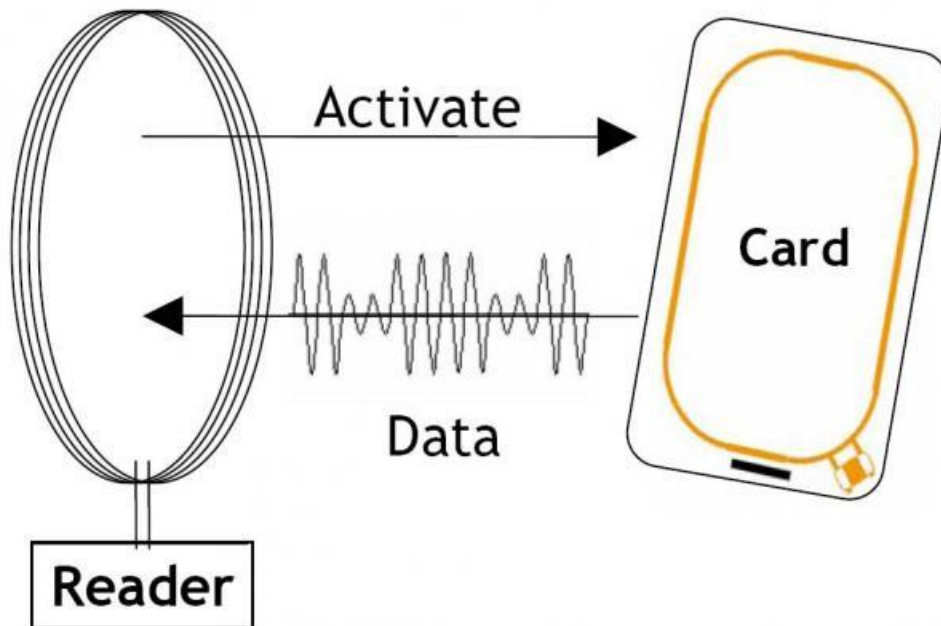

Fig 5.1 RFID system principle

Radio Frequency identification describes the system in which the identity of an individual or object is transmitted by means of a unique serial number through radio waves. Usually RFID system consists of two basic components they are

- Tag
- Reader

RFID tags consists of a simple Microchip which stores 12 byte unique ID and an antenna through which the unique ID is read by the reader. Whereas Reader is nothing but a specifically designed hardware module that senses the tag whenever it brought within a specific range say for example 10cms. The reader emit radio waves and receive signals back from the tag which comes with different operating frequency and sensing distance.

When a RFID tag is brought within the specific range of the reader the unique ID is sensed. After reading the ID from the tag is read by the reader and then that unique id is passed onto a controller/processor. The controller in turn performs specific action using that ID based on the written code.



Fig. 5.2 EM-18 RFID MODULE

### 5.3 Working of EM-18 RFID module

The module radiates 125KHz through its coils and when a 125KHz passive RFID tag is brought into this field it will get energized from this field. These passive RFID tags mostly consist of CMOS IC EM4102 which can get enough power for its working from the field generated by the reader.

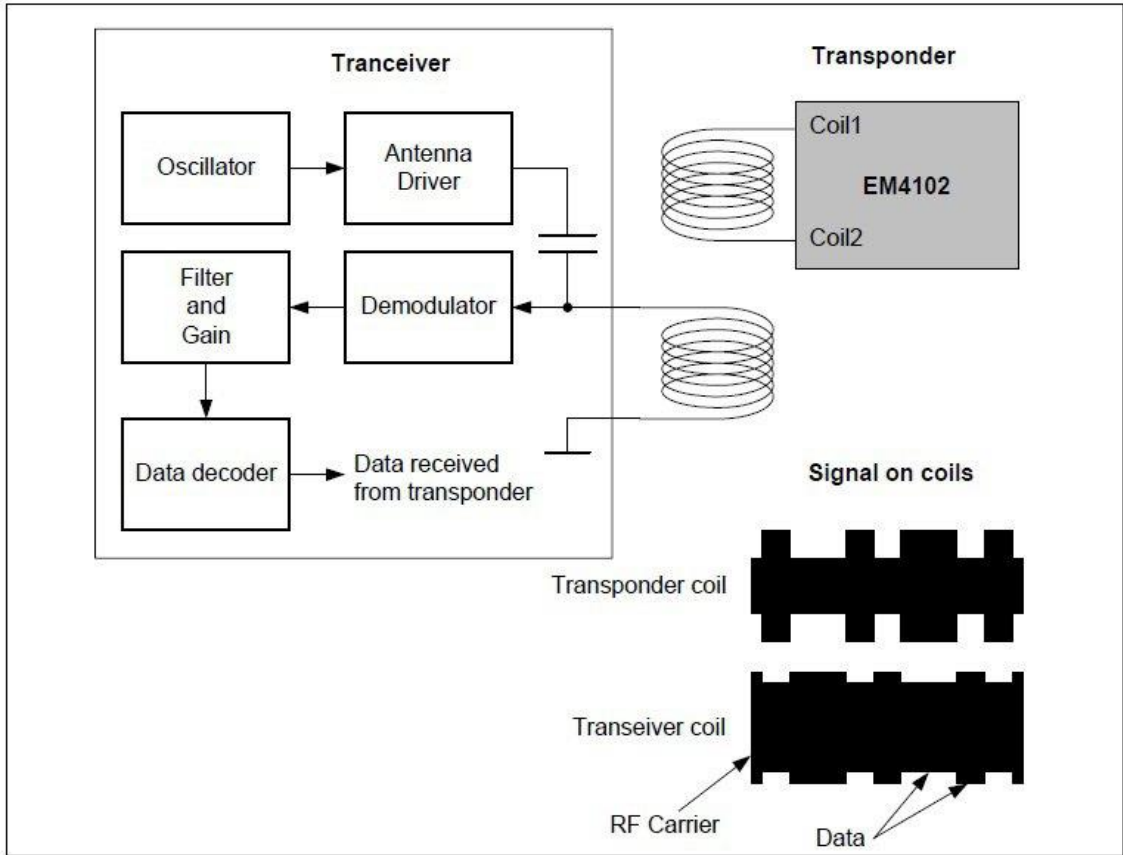

Fig 5.3 RFID – System Principle(2)

By changing the modulation current through the coils, tag will send back the information contained in the factory programmed memory array.

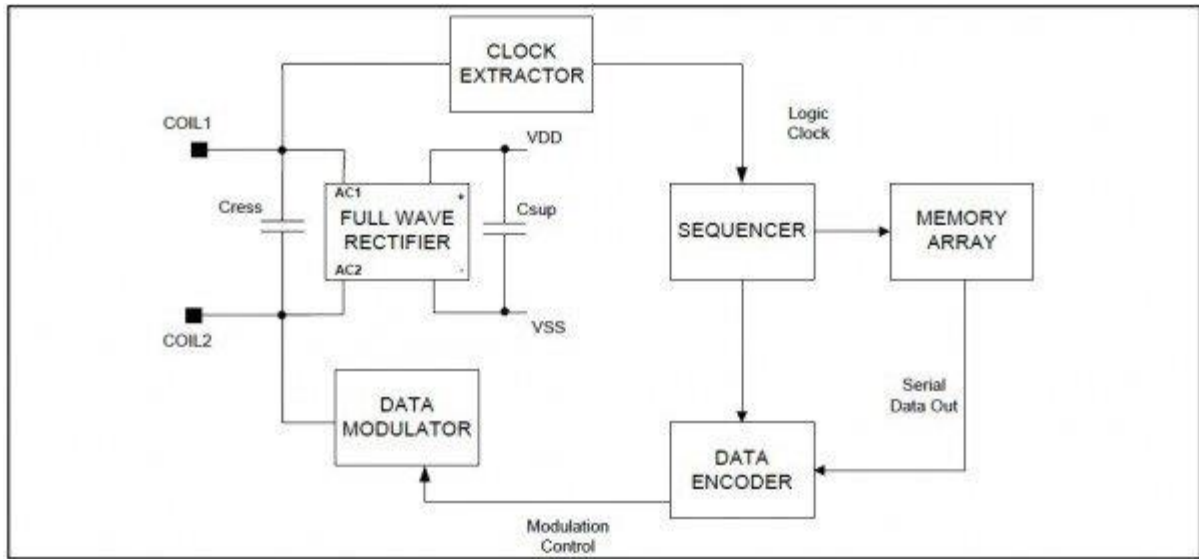

Fig 5.4 Passive RFID Tag Block Diagram

## 5.4 Pin Out

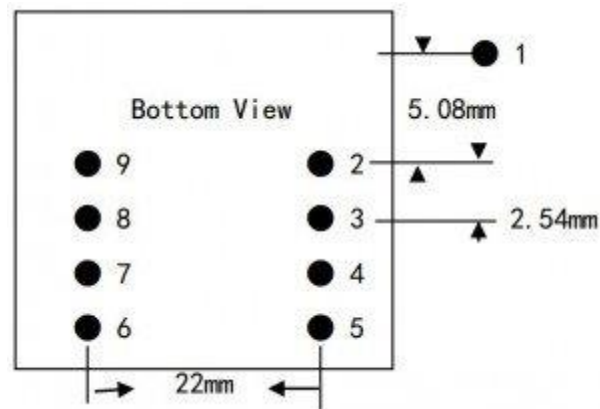
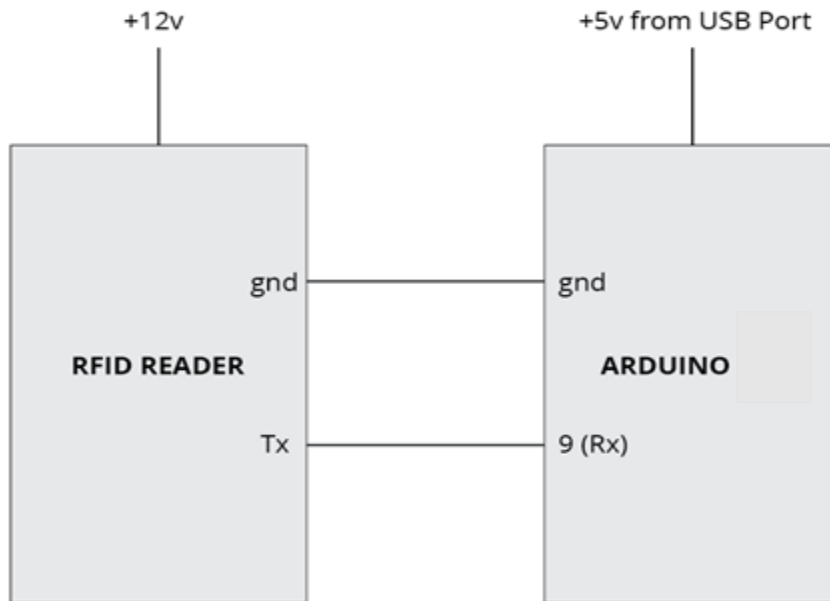

Fig 5.5EM-18 RFID Reader Module – Bottom View

Pin No.	Name	Function
1	VCC	5V
2	GND	Ground
3	BEEP	BEEP and LED
4	ANT	No Use
5	ANT	No Use
6	SEL	HIGH selects RS232, LOW selects WEIGAND
7	TX	UART TX, When RS232 is Selected
8	D1	WIEGAND Data 1
9	D0	WIEGAND Data 0

Table 5.1 Pin decription of RFID EM18

## 5.5 CIRCUIT DIAGRAM



### *Interfacing RFID Reader to Arduino*

Fig 5.6 Rfid interfacing with AVR

### Breadboard Wiring

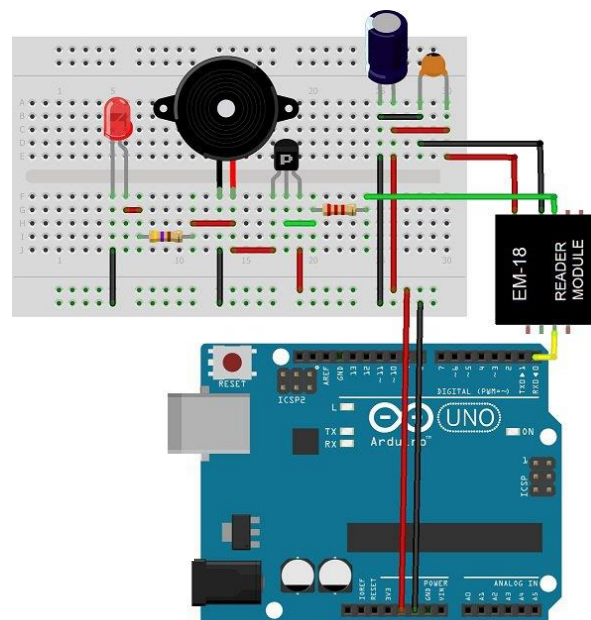

Fig.5.7 Interfacing EM-18 RFID Reader with Arduino – Breadboard Wiring

## 5.6 ARDUINO SERIAL MONITOR RFID OUTPUT

The output consists of 12 character ASCII data, where first 10 bits will be the tag number and last 2 bits will be the XOR result of the tag number which can be used for error correction. For eg : If the RFID tag number is 500097892E, output of EM-18 Reader will be 500097892E60, where **60** is **50 xor 00 xor 97 xor 89 xor 2E**.

---

**GSM interfacing with ATmega328**

**6.1 INTRODUCTION**

GSM is used not only for communication but also for call management in telecommunication field. It is used as a wireless communication which is suitable for mobile communication, in DATA Card for wireless internet connection. GSM has different types of speed, which are divided as a 1G, 2G, 3G & 4G. A large amount of data can be transferred through the GSM due to its TDMA & FDMA access. GSM Technique is also used as a security system in any particular area which gives an alert sms when any unsecured event occurs (traffic security, alarm systems) also in indicators which gives an alarm, when any condition is matched.



Fig.6.1 GSM SIM900A

GSM/GPRS MODEM TTL is built with dual band GSM/GPRS engine SIM900A, works on frequencies 900/ 1800 MHZ. It is suitable for SMS. Voice as well as DATA transfer application in Mobile2Mobile interface, Mobile2Device interface, Device2Mobile interface. The Baud rate is configurable from 9600-115200 through AT command .

GSM (Global System for Mobile Communication) technology lets user to communicate with others across mobile networks hence it offers a vast area of coverage. Interfacing GSM technology with microcontroller will enable us to extend the communication to cover large area. Interfacing of GSM modem with ATmega Microcontroller



Fig 6,2 SIM900A MODULE

- Designing of AVR Atmega Board
- Testing of AVR board with GSM modem
- Sending of text message using AVR Board

### **6.2 GSM NETWORK ARCHITECTURE:**

The GSM network architecture is now well established and with the other later cellular systems now established and other new ones being deployed, the basic GSM network architecture has been updated to interface to the network elements required by these systems.

Despite the developments of the newer systems, the basic GSM system architecture has been maintained, and the network elements described below perform the same functions as they did earlier.

GSM network architecture as defined in the GSM specifications can be grouped into four main areas:

- Mobile station (MS)
- Base-Station Subsystem (BSS)
- Network and Switching Subsystem (NSS)
- Operation and Support Subsystem (OSS)

The different elements of the GSM network operate together and the user is not aware of the different entities within the system.

A basic diagram of the overall GSM system architecture with these four major elements is shown below:



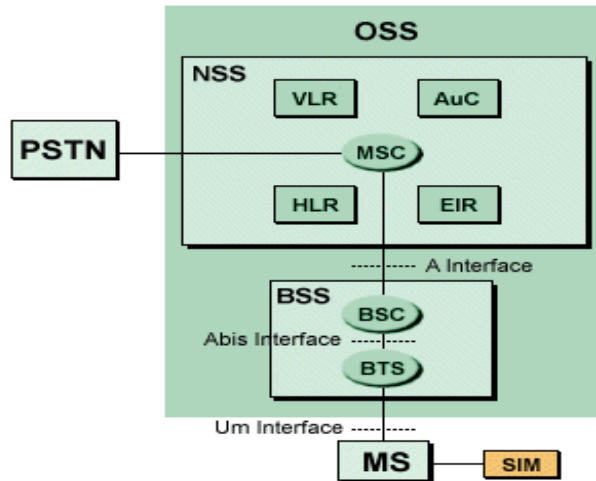

Fig 6.3 GSM system architecture

- **Mobile station:**

Mobile stations (MS), mobile equipment (ME) or as they are most widely known, cell or mobile phones are the section of a GSM cellular network that the user sees and operates. In recent years their size has fallen dramatically while the level of functionality has greatly increased. A further advantage is that the time between charges has significantly increased.

There are a number of elements to the cell phone, although the two main elements are the main hardware and the SIM.

The hardware itself contains the main elements of the mobile phone including the display, case, battery, and the electronics used to generate the signal, and process the data receiver and to be transmitted. It also contains a number known as the International Mobile Equipment Identity (IMEI). This is installed in the phone at manufacture and "cannot" be changed. It is accessed by the network during registration to check whether the equipment has been reported as stolen.

The SIM or Subscriber Identity Module contains the information that provides the identity of the user to the network. It contains a variety of information including a number known as the International Mobile Subscriber Identity (IMSI).

- **Base Station Subsystem (BSS):**

The Base Station Subsystem (BSS) section of the GSM network architecture that is fundamentally associated with communicating with the mobiles on the network. It consists of two elements:

- **Base Transceiver Station (BTS):** The BTS used in a GSM network comprises the radio transmitter receivers, and their associated antennas that transmit and

receive to directly communicate with the mobiles. The BTS is the defining element for each cell. The BTS communicates with the mobiles and the interface between the two is known as the Um interface with its associated protocols.

- **Base Station Controller (BSC):** The BSC forms the next stage back into the GSM network. It controls a group of BTSs, and is often co-located with one of the BTSs in its group. It manages the radio resources and controls items such as handover within the group of BTSs, allocates channels and the like. It communicates with the BTSs over what is termed the Abis interface.

- **Network Switching Subsystem (NSS)**

The GSM system architecture contains a variety of different elements, and is often termed the core network. It provides the main control and interfacing for the whole mobile network. The major elements within the core network include:

- **Mobile Switching services Centre (MSC):** The main element within the core network area of the overall GSM network architecture is the Mobile switching Services Centre (MSC). The MSC acts like a normal switching node within a PSTN or ISDN, but also provides additional functionality to enable the requirements of a mobile user to be supported. These include registration, authentication, call location, inter-MSC handovers and call routing to a mobile subscriber. It also provides an interface to the PSTN so that calls can be routed from the mobile network to a phone connected to a landline. Interfaces to other MSCs are provided to enable calls to be made to mobiles on different networks.
- **Home Location Register (HLR):** This database contains all the administrative information about each subscriber along with their last known location. In this way, the GSM network is able to route calls to the relevant base station for the MS. When a user switches on their phone, the phone registers with the network and from this it is possible to determine which BTS it communicates with so that incoming calls can be routed appropriately. Even when the phone is not active (but switched on) it re-registers periodically to ensure that the network (HLR) is aware of its latest position. There is one HLR per network, although it may be distributed across various sub-centres to for operational reasons.
- **Visitor Location Register (VLR):** This contains selected information from the HLR that enables the selected services for the individual subscriber to be provided. The VLR can be implemented as a separate entity, but it is commonly realised as an integral part of the MSC, rather than a separate entity. In this way access is made faster and more convenient.
- **Equipment Identity Register (EIR):** The EIR is the entity that decides whether a given mobile equipment may be allowed onto the network. Each mobile equipment has a

number known as the International Mobile Equipment Identity. This number, as mentioned above, is installed in the equipment and is checked by the network during registration. Dependent upon the information held in the EIR, the mobile may be allocated one of three states - allowed onto the network, barred access, or monitored in case its problems.

- **Authentication Centre (AuC):** The AuC is a protected database that contains the secret key also contained in the user's SIM card. It is used for authentication and for ciphering on the radio channel.
- **Gateway Mobile Switching Centre (GMSC):** The GMSC is the point to which a ME terminating call is initially routed, without any knowledge of the MS's location. The GMSC is thus in charge of obtaining the MSRN (Mobile Station Roaming Number) from the HLR based on the MSISDN (Mobile Station ISDN number, the "directory number" of a MS) and routing the call to the correct visited MSC. The "MSC" part of the term GMSC is misleading, since the gateway operation does not require any linking to an MSC.
- **SMS Gateway (SMS-G):** The SMS-G or SMS gateway is the term that is used to collectively describe the two Short Message Services Gateways defined in the GSM standards. The two gateways handle messages directed in different directions. The SMS-GMSC (Short Message Service Gateway Mobile Switching Centre) is for short messages being sent to an ME. The SMS-IWMSC (Short Message Service Inter-Working Mobile Switching Centre) is used for short messages originated with a mobile on that network. The SMS-GMSC role is similar to that of the GMSC, whereas the SMS-IWMSC provides a fixed access point to the Short Message Service Centre.

### **Operation and Support Subsystem (OSS)**

The OSS or operation support subsystem is an element within the overall GSM network architecture that is connected to components of the NSS and the BSC. It is used to control and monitor the overall GSM network and it is also used to control the traffic load of the BSS. It must be noted that as the number of BS increases with the scaling of the subscriber population some of the maintenance tasks are transferred to the BTS, allowing savings in the cost of ownership of the system.

## **6.3 STEPS TO INTERFACE GSM MODEM WITH MICROCONTROLLER:**

### **STEP 1: MODEM TESTING:**

The Modem consists of two indicating LED's Green and Red to indicate the availability of the network. Green indicates the availability of the network whereas red indicates its absence. Turn the modem ON and wait for sometime to register itself in GSM network.

## STEP 2: INTERFACING WITH AVR MICROCONTROLLER:

The Communication between AVR and modem takes place through USART protocol. GSM Modem SIM900 works on TTL level hence we can interface directly to RXD and TXD pins of AVR microcontroller. There is no need of using Voltage or level converter between them. However if you ever happen to buy a SIM300 or other module which operates above TTL level, you may want to use MAX232 level converter IC to make the communication possible.

## STEP 3: INITIALIZING MODEM:

The modem must be Initialized using the commands and then the process you are about to carry out must be selected.

## 6.4 CIRCUIT DIAGRAM

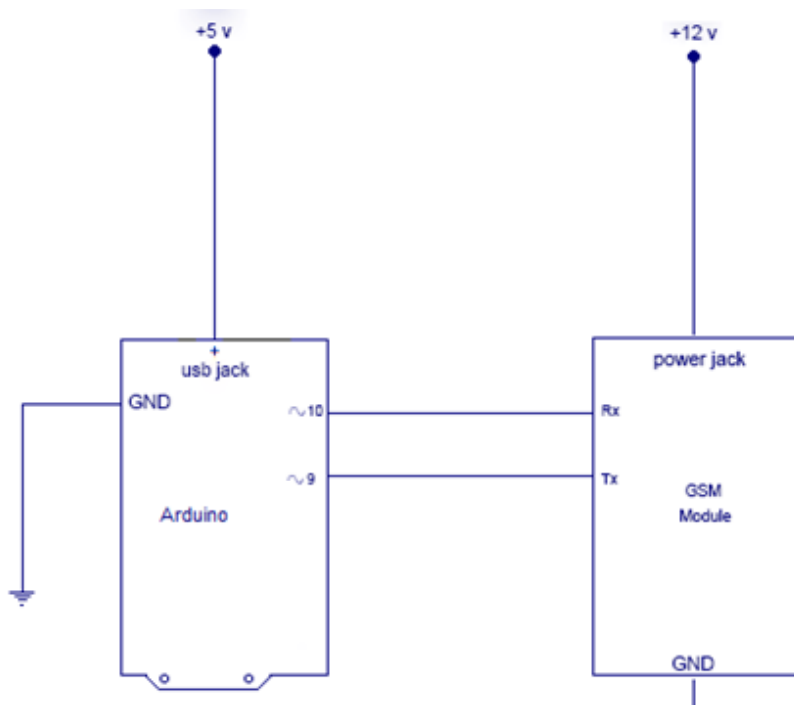

Fig.6.4 Circuit for GSM interfacing with arduino

## **RESULTS AND CONCLUSIONS**

The project has been successfully designed and implemented for the “**Design of women safety device using RFID and GSM based technology**” It has been developed by integrating features of all the hardware components used. Presence of every module has been reasoned out and placed carefully thus contributing to the best working of the unit.

Secondly, using highly advanced IC's and with the help of growing technology the project has been successfully implemented and tested.

## *REFERENCES*

---

### **Research papers:**

1. Nishant Bhardwaj and Nitish Aggarwal- “Design and development of ‘SURAKSHA’- a women safety device” *International Journal of Information & Computation Technology. ISSN 0974-2239 Volume 4, Number 8 (2014), pp. 787-792* © *International Research Publications House* <http://www.irphouse.com>
  
2. Shaik Mazhar Hussain and Shaik Jhani Bhasha “Design of women safety system using RFID, 8051microcontroller and GSM based technology a prototype” - *International Journal of Advanced Research in Computer and Communication Engineering Vol. 3, Issue 6, June 2014*

### **Web:**

- <https://en.wikipedia.org/wiki/ATmega328>
- <http://www.engineersgarage.com/embedded/avr-microcontroller-projects/rfid-interfacing-circuit>
- <http://www.engineersgarage.com/contribution/how-to-interface-GSM-SIM-300-modem-with-atmega32-to-send-and-receive-SMS>
- <https://electrosome.com/em-18-rfid-reader-arduino-uno/>
- <http://circuitdigest.com/microcontroller-projects/rfid-with-arduino-uno-tutorial>
- [http://www.circuitstoday.com/wp-content/uploads/2015/03/Interfacing\\_RFID\\_to\\_Arduino.png](http://www.circuitstoday.com/wp-content/uploads/2015/03/Interfacing_RFID_to_Arduino.png)
- <http://www.instructables.com/id/Arduino-and-RFID-from-seeedstudio/>

## Microcontroller ATMEGA328 Datasheet

### Pin Diagram:

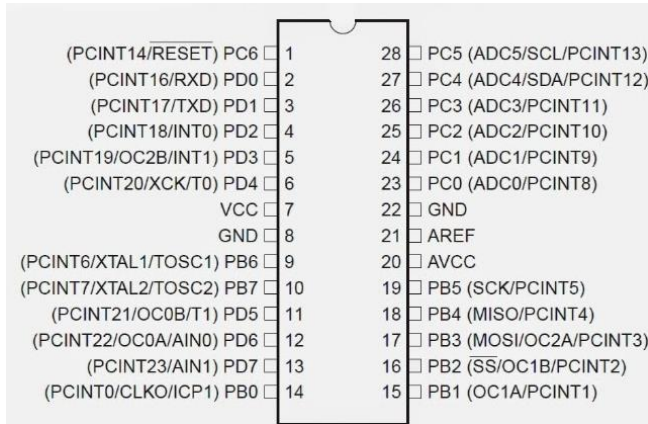

### Pin Description:

Pin Number	Description	Function
1	PC6	Reset
2	PD0	Digital Pin (RX)
3	PD1	Digital Pin (TX)
4	PD2	Digital Pin
5	PD3	Digital Pin (PWM)
6	PD4	Digital Pin
7	Vcc	Positive Voltage (Power)
8	GND	Ground
9	XTAL 1	Crystal Oscillator
10	XTAL 2	Crystal Oscillator
11	PD5	Digital Pin (PWM)
12	PD6	Digital Pin (PWM)
13	PD7	Digital Pin
14	PB0	Digital Pin
15	PB1	Digital Pin (PWM)
16	PB2	Digital Pin (PWM)
17	PB3	Digital Pin (PWM)
18	PB4	Digital Pin

19	PB5	Digital Pin
20	AVCC	Positive voltage for ADC (power)
21	AREF	Reference Voltage
22	GND	Ground
23	PC0	Analog Input
24	PC1	Analog Input
25	PC2	Analog Input
26	PC3	Analog Input
27	PC4	Analog Input
28	PC5	Analog Input

20 of the pins function as I/O ports. This means they can function as an input to the circuit or as output. Whether they are input or output is set in the software. 14 of the pins are digital pins, of which 6 can function to give PWM output. 6 of the pins are for analog input/output.

2 of the pins are for the crystal oscillator. This is to provide a clock pulse for the Atmega chip. A clock pulse is needed for synchronization so that communication can occur in synchrony between the Atmega chip and a device that it is connected to.

The chip needs power so 2 of the pins, Vcc and GND, provide it power so that it can operate. The Atmega328 is a low-power chip, so it only needs between 1.8-5.5V of power to operate.

The Atmega328 chip has an analog-to-digital converter (ADC) inside of it. This must be or else the Atmega328 wouldn't be capable of interpreting analog signals. Because there is an ADC, the chip can interpret analog input, which is why the chip has 6 pins for analog input. The ADC has 3 pins set aside for it to function- AVCC, AREF, and GND. AVCC is the power supply, positive voltage, that for the ADC. The ADC needs its own power supply in order to work. GND is the power supply ground. AREF is the reference voltage that the ADC uses to convert an analog signal to its corresponding digital value. Analog voltages higher than the reference voltage will be assigned to a digital value of 1, while analog voltages below the reference voltage will be assigned the digital value of 0. Since the ADC for the Atmega328 is a 10-bit ADC, meaning it produces a 10-bit digital value, it converts an analog signal to its digital value, with the AREF value being a reference for which digital values are high or low. Thus, a portrait of an analog signal is shown by this digital value; thus, it is its digital correspondent value.

The last pin is the RESET pin. This allows a program to be rerun and start over.



### **CODE:**

```
#include "projectgsm.h"

#define FONA_RX 2
#define FONA_TX 3
#define FONA_RST 4

#include <SoftwareSerial.h>
SoftwareSerial fonaSS = SoftwareSerial(FONA_TX, FONA_RX);
SoftwareSerial *fonaSerial = &fonaSS;
projectgsm fona = projectgsm(FONA_RST);

String card="$0005074228";
String msg;
char c;

void setup() {
  pinMode(7,OUTPUT);
  digitalWrite(7,HIGH);
  delay(1200);
  digitalWrite(7,LOW);

  while (!Serial);

  Serial.begin(9600);
  Serial.println(F("FONA SMS caller ID test"));
  Serial.println(F("Initializing....(May take 3 seconds)"));

  fonaSerial->begin(9600);
  if (! fona.begin(*fonaSerial)) {
    Serial.println(F("Couldn't find FONA"));
    while(1);
  }
  Serial.println(F("FONA is OK"));

  char imei[15] = {0}; // MUST use a 16 character buffer for IMEI!
  uint8_t imeiLen = fona.getIMEI(imei);
  if (imeiLen > 0) {
    Serial.print("SIM card IMEI: "); Serial.println(imei);
  }

  Serial.println("FONA Ready");
  fona.sendSMS("9882849315", "RFID Safty Enabled");

}
```

```
void loop() {  
  
  msg="";  
  while(msg.length()<13)  
  {  
    while(Serial.available()>0){  
      c=Serial.read();  
      msg += c;  
    }  
  }  
  Serial.print(msg);  
  
  if(card.indexOf(msg))  
  {  
    fona.sendSMS("9882849315", "I am in Danger");  
  
    delay(200);  
    fona.sendSMS("8263975795", "I am in Danger");  
  }  
}
```

